



Geometric &
Vision Barriers

*See page 2 & 3
for our new
concept
in screening*



C/S New Prefabricated Econo-Line saves you time and money.

The quickest and easiest way to screen structures

- Economical screening system comes assembled to jobsite for easy installation
- Thinline appearance
- High free area means excellent ventilation
- Comes with our 20-year environmentally friendly powder coat finishes
- Close spacing provides excellent security

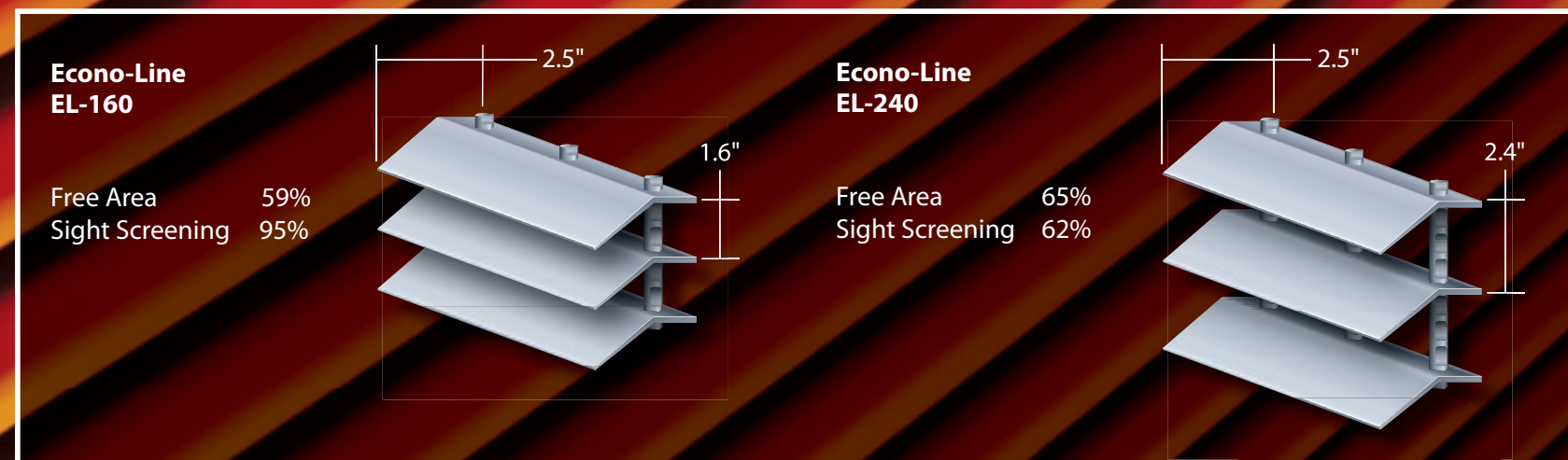

For over 50 years C/S has been the leader in Architectural Grilles. Our grilles serve a multitude of functions. They generally fit into one of the six categories below:

▼ **Decorative/Sight Screens** page 4

Used to cover an element of the building or provide a visual accent.

▼ **Parking Garage Screens** page 5

Provide a stunning facade allowing ventilation and exhaust to flow freely.

▼ **Re-Facing Systems** page 6

Used to provide a fresh and new facade to an existing building.

▼ **Equipment Screens** page 7

Continue a building's clean lines while hiding its necessary functional elements.

▼ **Geometric Grilles** pages 8-11

Twelve distinctive architectural grille designs that offer designers a variety of expression for decorative facing and sight-screening situations.

▼ **Vision Barriers** pages 12-15

C/S offers a wide variety of vision barriers and screening systems for use on parking garages, to reface buildings and to hide mechanical equipment.

The following pages show some great photos of how architects have used C/S Grilles in the past. Go ahead, be creative.

C/S Decorative Sight Screens

C/S Decorative Grilles have captured the interest and imagination of architects for over 50 years. C/S Grille designs are **both functional and decorative** and offer an intricate counterpoint to conventional building materials. All C/S Geometric Grilles are **manufactured to specific building requirements** and can be customized in dozens of ways, including altering the blade style, slope or frame and the finish of each pattern. C/S Grille engineers are ready to assist you in the selection of the proper system and method of anchorage for your specific project. Call (800) 631-7379 for details.

▼ Ashton Place
Dallas, TX
Product: Myriad XXX
Architect: Gromatsky
Dupree & Associates

► Republic Bank
Miami, FL
Product: Medallion Grilles
Architect: Spillis Candela
DMJM



C/S Parking Garage Screens

C/S Parking Garage Screens provide an aesthetic **architectural solution to the engineering problem of garage ventilation and vision control**. Capable of spanning large openings for multiple parking levels, C/S Parking Screens offer vision protection to adjacent buildings and the street below from automobile headlights. C/S Vision Barriers are offered in a wide array of patterns, varying in width depth and free area for adequate air exchange. From simple vertical lines to elaborate designs, C/S Parking Screens **can span normal floor levels without intermediate supports**.

▼ Linny Pacillo Parking Garage
Anchorage, AK
Products: VAC 8000, VAC
6000
Architect: Kpb Architects

► Fort Lauderdale Airport
Rental Car Facility
Fort Lauderdale, FL
Products: Vert-A-Cade 304,
Myriad Continuous,
Vert-A-Cade 8000
Architect: Spillis Candela
DMJM



► All C/S Decorative Grilles are available in a wide selection of frame options or can be installed in a continuous architectural line for a monolithic appearance. All C/S Grille connections are designed to be unobtrusive yet safely meet the building's wind loading requirements.

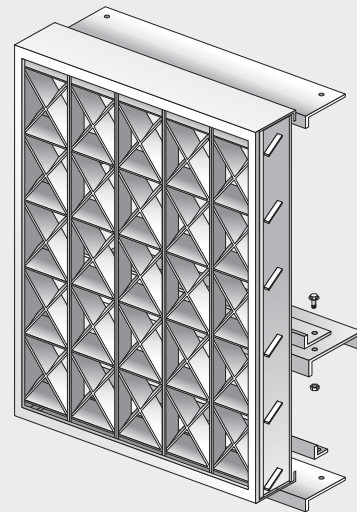

► Most C/S screening systems can be designed to satisfy parking garage code requirements for free area movement (ie, 50% open, no sprinkler system required). C/S has considerable experience designing connections to parking garages that allow for deck movement from both vehicles and movement associated with seismic activity.

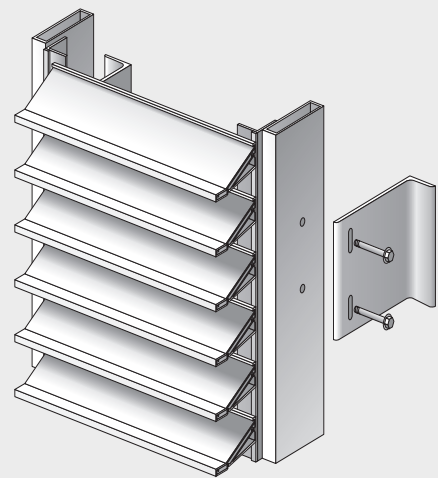

C/S Refacing Systems

The renovation of existing buildings is not only environmentally responsible but **refacing is also an economic alternative to developing a new structure**. C/S Refacing Systems are tailored to meet both the owner's budget and the building's architecture. The C/S Grille Design Group can provide the specifier with a **wide variety of refacing options to meet the project's functional requirements**, including which C/S Grille product is best suited to provide the appropriate coverage, free area and screening requirements.

▼ Office Building Cincinnati, OH
Product: Alumatex Tweed Pattern

► IJL Financial Center Charlotte, NC
Product: Myriad, Medallion and Modular Grilles
Architect: Smallwood, Reynolds, Stewart, Stewart



► A completely engineered system using linear blades, C/S Refacings allow architects to completely cover existing facades while allowing light and air to filter to the interior. C/S Refacing Systems can be designed to fit the condition of your building and allow for mounting to any surface.

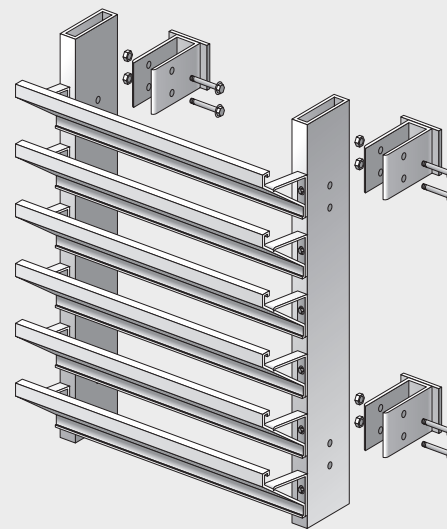

C/S Equipment Screens

C/S Equipment Screens are **designed to conceal any equipment that can spoil the appearance of a building**. Our equipment screens can be used on roof tops to screen air conditioning, heating and ventilation systems, or at ground level to enclose generators, waste bins or other auxiliary equipment. Offered in numerous vertical or horizontal designs, **these vision barriers integrate beautifully into the buildings architecture**. Height, width and blade spacing of each pattern provides the specifier with options for the amount of sight cut-off and free area that the screen will provide.

▼ Hybridon Headquarters, Cambridge, MA
Product: C/S Airfoil Rooftop Screen
Architect: Carlone & Associates

► Richmond Newspapers, Inc Richmond, VA
Product: Vert-A-Cade 300
Architect: Baskerville Architects



► C/S offers a variety of linear extruded aluminum profiles that can visually shield mechanical equipment while providing for adequate air flow to the equipment. Customization of the support and attachment hardware allows for application to almost any size equipment.

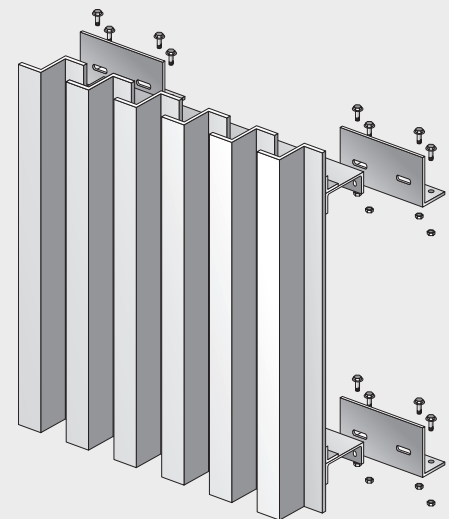

C / S VISION

Whatever the sight screening problem, there is a C/S Vision Barrier to do the job **attractively and effectively.** No one has a wider array of patterns. Custom profiles are also available.

C/S Vert-A-Cade®, Econoscreen® and Alumatex Screening Systems are ideal for use on parking garages, **concealing** mechanical equipment and for many refacing applications.

The Vert-A-Cade line is manufactured from **rugged extrusions**

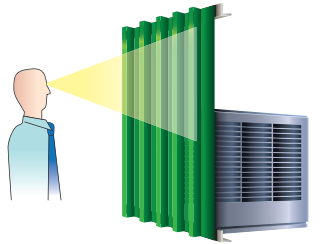

▲ C/S Vision Barriers can conceal everything from car lights in parking garages to rooftop mechanical equipment.

BARRIERS

in **numerous blade styles.** Econoscreen combines low initial cost with ease of installation, and Alumatex is capable of spanning large openings. All C/S Vision Barriers are available in a wide variety of architectural finishes. C/S offers **design and engineering services** and welcomes the opportunity to assist you. Call today (800) 631-7379. For downloadable CAD details, location photos and specifications for each grille, go to **www.c-sgroup.com.**

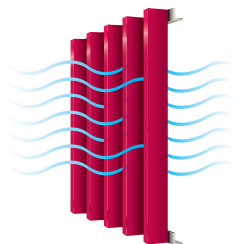

▲ All C/S Vision Barriers can be modified to provide your facility with the required amount of free area.

C/S Vision Barriers

VERT-A-CADE 301

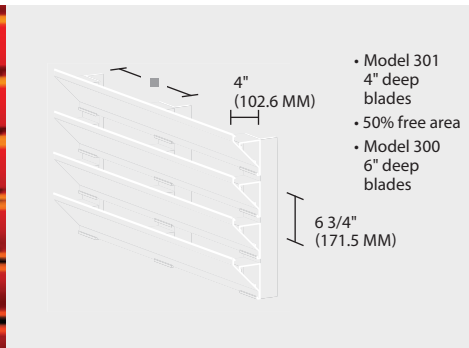

ECONO-LINE EL-240 EL-160

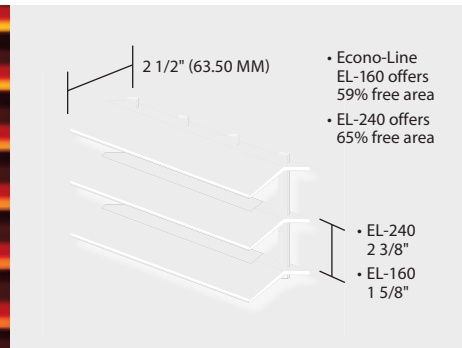

ECONOSCREEN RF-20

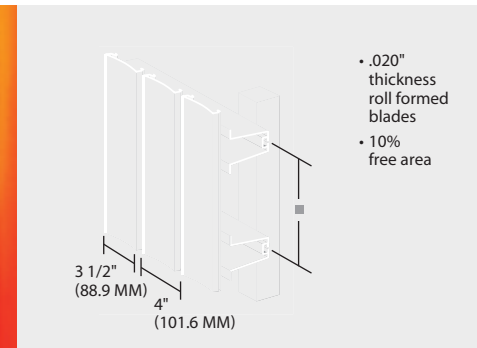
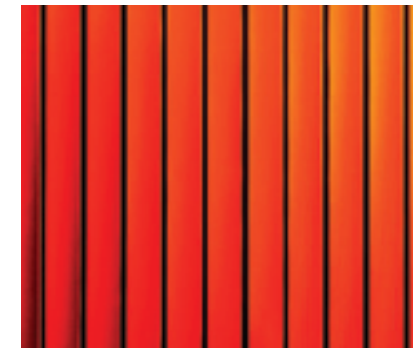

VERT-A-CADE 304

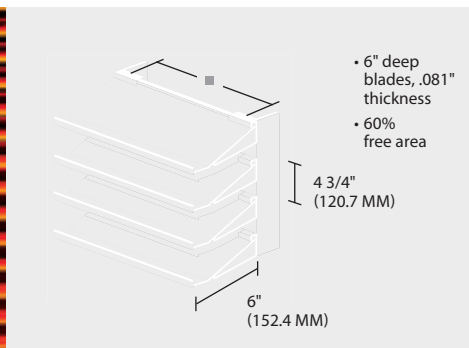
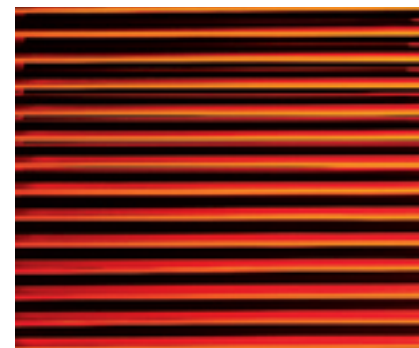

VERT-A-CADE 1000

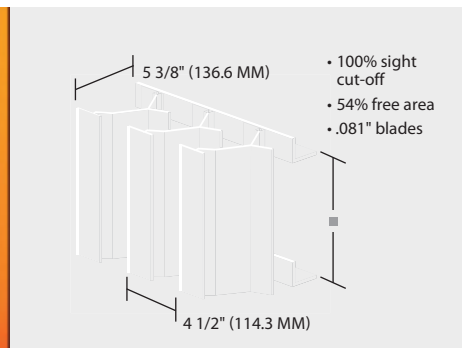
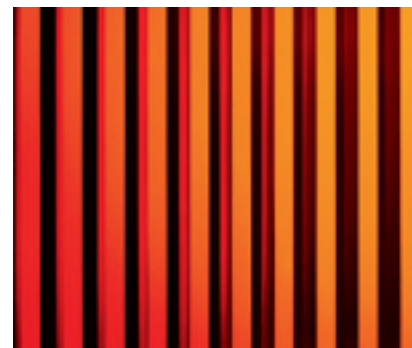

ECONOSCREEN RV-20

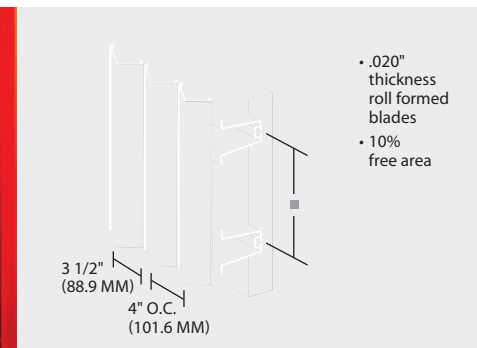
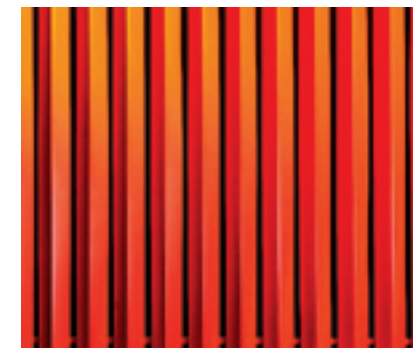

VERT-A-CADE 400

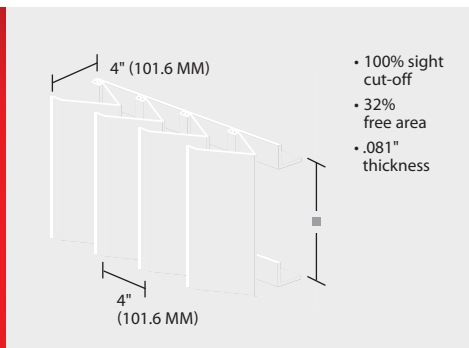

VERT-A-CADE 1100

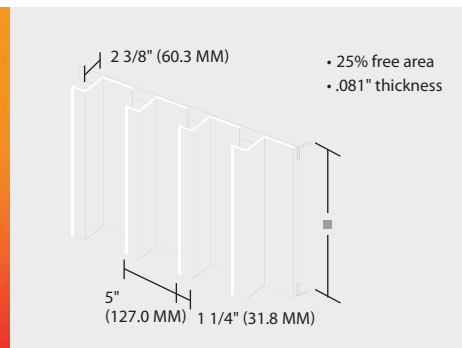

ALUMATEX TWEED

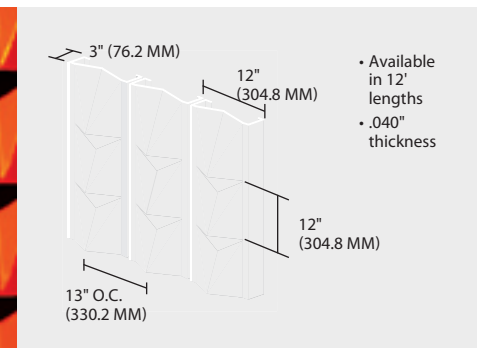

VERT-A-CADE 500

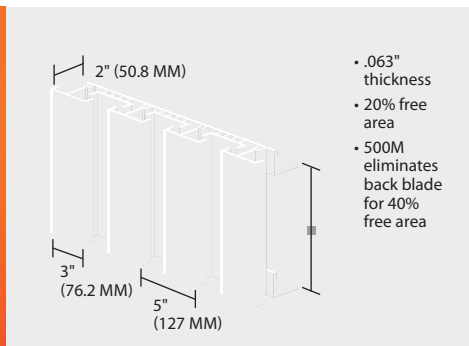

VERT-A-CADE 8000

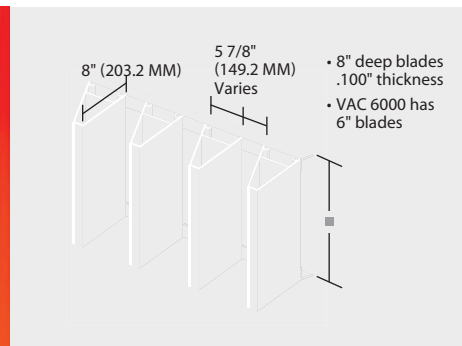
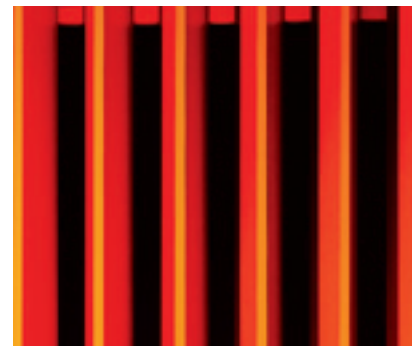

ALUMATEX MADRAS

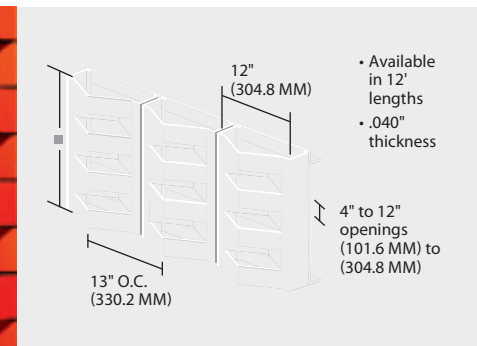

■ Varies based on wind loading requirements.

■ Varies based on wind loading requirements.

🔗 For comprehensive information on these products, visit www.c-sgroup.com/geometricgrilles